

# HYDROBOOTH OUTSIDE DIMENSIONS

TYPE-VENTED *	BOOTH SELECTION	STANDARD X x Y x Z	WITH A 1 FT. BUMP X x Y x Z	WITH A 2 FT. BUMP X x Y x Z
*	B40	44 <sup>3</sup> / <sub>8</sub> " X 45 <sup>1</sup> / <sub>4</sub> " X 81 <sup>1</sup> / <sub>2</sub> "	44 <sup>3</sup> / <sub>8</sub> " X 45 <sup>1</sup> / <sub>4</sub> " X 93 <sup>1</sup> / <sub>2</sub> "	44 <sup>3</sup> / <sub>8</sub> " X 45 <sup>1</sup> / <sub>4</sub> " X 105 <sup>1</sup> / <sub>2</sub> "
*	B60	64 <sup>3</sup> / <sub>8</sub> " X 45 <sup>1</sup> / <sub>4</sub> " X 81 <sup>1</sup> / <sub>2</sub> "	64 <sup>3</sup> / <sub>8</sub> " X 45 <sup>1</sup> / <sub>4</sub> " X 93 <sup>1</sup> / <sub>2</sub> "	64 <sup>3</sup> / <sub>8</sub> " X 45 <sup>1</sup> / <sub>4</sub> " X 105 <sup>1</sup> / <sub>2</sub> "
*	B72	76 <sup>3</sup> / <sub>8</sub> " X 45 <sup>1</sup> / <sub>4</sub> " X 81 <sup>1</sup> / <sub>2</sub> "	76 <sup>3</sup> / <sub>8</sub> " X 45 <sup>1</sup> / <sub>4</sub> " X 93 <sup>1</sup> / <sub>2</sub> "	76 <sup>3</sup> / <sub>8</sub> " X 45 <sup>1</sup> / <sub>4</sub> " X 105 <sup>1</sup> / <sub>2</sub> "
*	B84	88 <sup>3</sup> / <sub>8</sub> " X 45 <sup>1</sup> / <sub>4</sub> " X 81 <sup>1</sup> / <sub>2</sub> "	88 <sup>3</sup> / <sub>8</sub> " X 45 <sup>1</sup> / <sub>4</sub> " X 93 <sup>1</sup> / <sub>2</sub> "	88 <sup>3</sup> / <sub>8</sub> " X 45 <sup>1</sup> / <sub>4</sub> " X 105 <sup>1</sup> / <sub>2</sub> "
*	B96	100 <sup>3</sup> / <sub>8</sub> " X 45 <sup>1</sup> / <sub>4</sub> " X 81 <sup>1</sup> / <sub>2</sub> "	100 <sup>3</sup> / <sub>8</sub> " X 45 <sup>1</sup> / <sub>4</sub> " X 93 <sup>1</sup> / <sub>2</sub> "	100 <sup>3</sup> / <sub>8</sub> " X 45 <sup>1</sup> / <sub>4</sub> " X 105 <sup>1</sup> / <sub>2</sub> "
*	B120	124 <sup>3</sup> / <sub>8</sub> " X 45 <sup>1</sup> / <sub>4</sub> " X 81 <sup>1</sup> / <sub>2</sub> "	124 <sup>3</sup> / <sub>8</sub> " X 45 <sup>1</sup> / <sub>4</sub> " X 93 <sup>1</sup> / <sub>2</sub> "	124 <sup>3</sup> / <sub>8</sub> " X 45 <sup>1</sup> / <sub>4</sub> " X 105 <sup>1</sup> / <sub>2</sub> "

## \*STANDARD INSIDE DIMENSIONS

BOOTH TYPE	*STANDARD INSIDE DIMENSIONS		*WITH A 1 FT. BUMP INSIDE DIMENSIONS		*WITH A 2 FT. BUMP INSIDE DIMENSIONS	
	HEIGHT "H"	WIDTH "W"	HEIGHT "H"	WIDTH "W"	HEIGHT "H"	WIDTH "W"
*B40	34 3/4"	29 1/2"	46 3/4"	29 1/2"	58 3/4"	29 1/2"
*B60	34 3/4"	49 1/2"	46 3/4"	49 1/2"	58 3/4"	49 1/2"
*B72	34 3/4"	61 1/2"	46 3/4"	61 1/2"	58 3/4"	61 1/2"
*B84	34 3/4"	83 1/2"	46 3/4"	83 1/2"	58 3/4"	83 1/2"
*B96	34 3/4"	85 1/2"	46 3/4"	85 1/2"	58 3/4"	85 1/2"
*B120	34 3/4"	109 1/2"	46 3/4"	109 1/2"	58 3/4"	109 1/2"

## MAXIMUM SCREEN BAR WIDTH DIMENSIONS

BOOTH TYPE	WIDTH "B"
*B40	36"
*B60	56"
*B72	68"
*B84	90"
*B96	92"
*B120	116"

## MAXIMUM SCREEN HEIGHT DIMENSIONS

BOOTH TYPE	HEIGHT "S"
*B40	48"
*B60	59"
*B72	70 5/16"
*B84	81 13/16"
*B96	93 7/16"
*B120	106 5/16"

**DIMENSION TABLE A**

APPLICATIONS OF EXHAUST FANS & DIMENSIONS	FAN SIZE	INSIDE DIA.	BOLT CIRCLE DIA.	FLANGE DIA.
ONLY THE B40, B60, & B72 HYDROBOOTHs	16"	16 3/32"	17 1/2"	18 3/4"
ONLY THE B96 & B120 HYDROBOOTHs	18"	18 1/2"	19 7/8"	21 1/8"

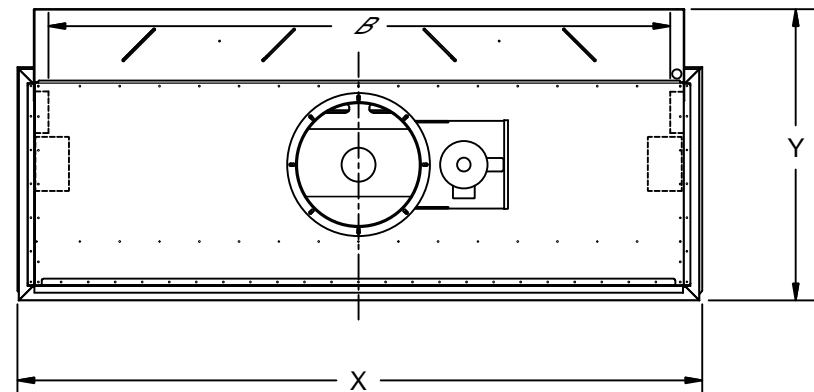

**NOTE:** FOR OUTSIDE DIMENSIONS OF HYDROBOOTH, SEE TABLE A.

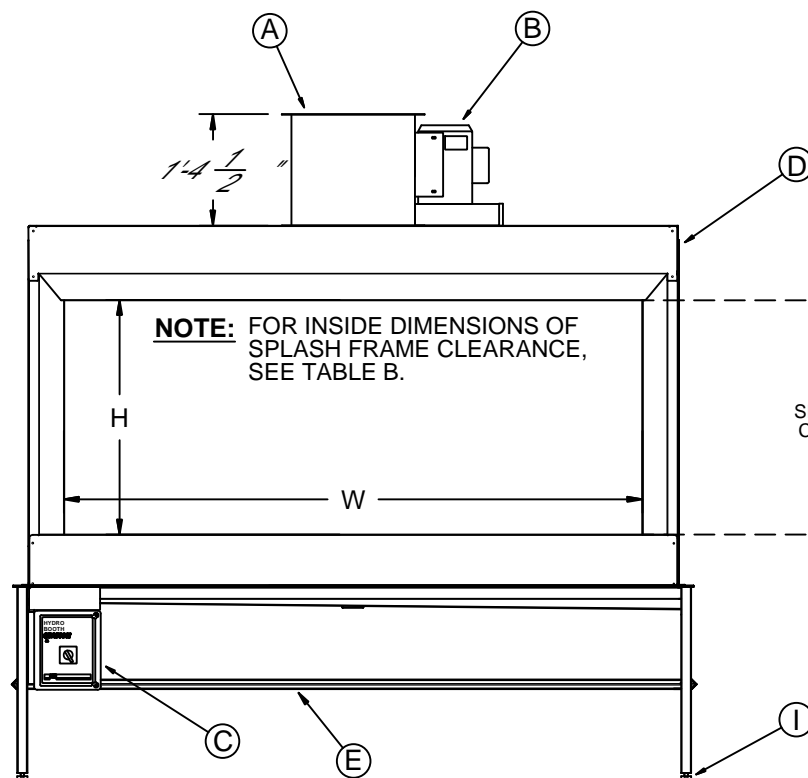

**NOTE:** FOR INSIDE DIMENSIONS OF SPLASH FRAME CLEARANCE, SEE TABLE B.

SPLASH FRAME CLEARANCE

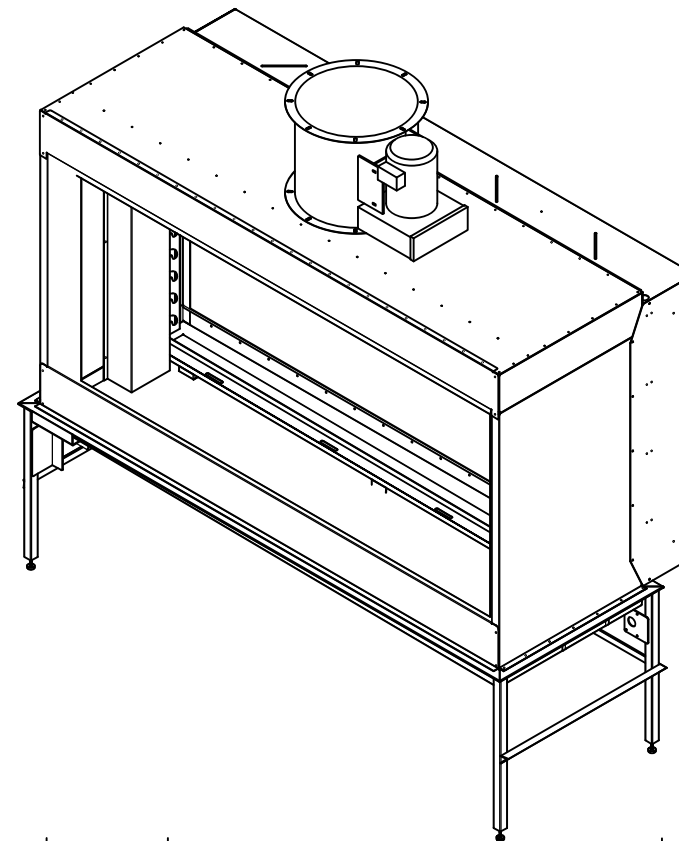

**DIMENSION TABLE B**

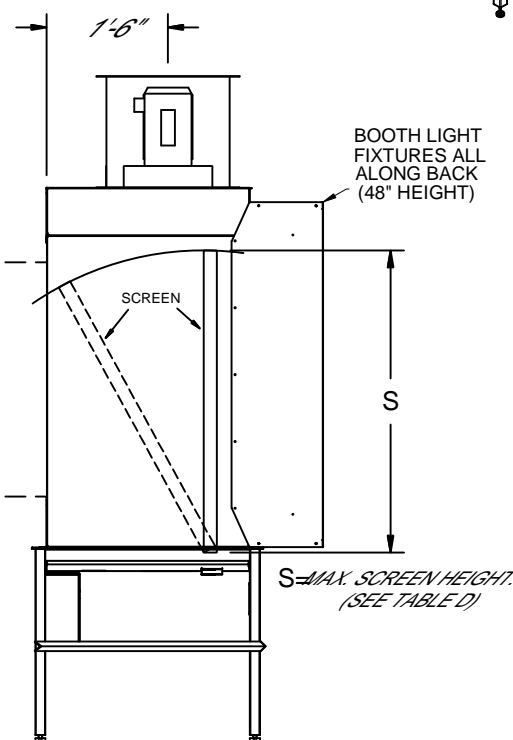

BOOTH LIGHT FIXTURES ALL ALONG BACK (48" HEIGHT)

SCREEN

S=MAX. SCREEN HEIGHT (SEE TABLE D)

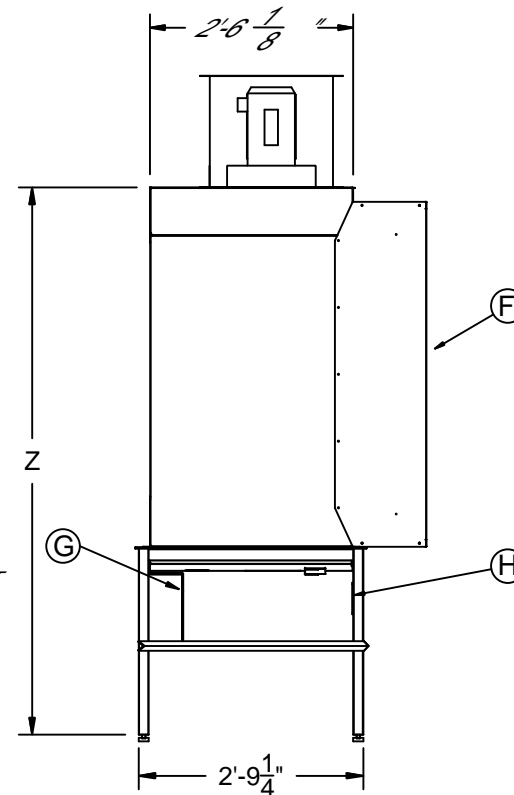

2'-9 1/4"

## INSTALLATION REQUIREMENTS & NOTES

1. THE HYDROBOOTH MAY BE PLACED WITH THE BACKSIDE CLOSE TO THE WALL OR OUT IN THE OPEN (AS LONG AS CONNECTION POINTS CAN BE ACCESSED). ENOUGH ACCESS CLEARANCE SHOULD BE PROVIDED FOR HOSE & ELECTRICAL CONNECTIONS. RECOMMENDED MINIMUM REAR SPACING FROM WALL, 18", OR ENOUGH TO ALLOW FOR ACCESS TO LIGHTS FOR MAINTENANCE.
2. PIPE AND CONDUIT RUNS ARE TO BE ROUTED TO APPROPRIATE HOOKUP LOCATIONS. A SUMP BOX w/PUMP POSITIONED DIRECTLY UNDER GATE VALVE AT SINK DRAIN IS A TYPICAL SETUP OPTION ORDERED WITH BOOTHS. OUTFLOW FROM SINK IS LEFT TO THE DISCRETION OF THE CUSTOMER AT THE TIME ORDER. GATE VALVE PROVIDED AT SINK DRAIN IS SIZED FOR 1-1/2" PVC SLIP CONNECTION.  
  
FLEX-CONDUIT, SIZED & PROVIDED BY QUALIFIED ELECTRICIAN TO BE ROUTED INTO CONTROL BOX FROM DESIGNATED SUPPLY GANG BOX PER APPLICABLE CODES. USE APPROPRIATE ELECTRICAL DIAGRAMS TO MAKE CONNECTIONS.
3. SECURING OF HYDROBOOTH TO GROUND / FLOOR OR WALL IS ALSO LEFT TO THE DETERMINATION OF NEED BY THE CUSTOMER.

## COMPONENT IDENTIFICATION

- (A) EXHAUST FAN. (SEE TABLE)
- (B) FAN MOTOR
- (C) CONTROL BOX
- (D) HYDROBOOTH HOUSING
- (E) HYDROBOOTH STAND
- (F) LIGHT HOUSING
- (G) CONTROL BOX PANEL
- (H) ELECTRICAL GANG BOX
- (I) FRAME GLIDE FEET (QTY: 4-6) DEPENDING ON SIZE OF BOOTH (GLIDE FEET HEIGHT NOT INCLUDED IN DIMENSIONAL TABLES)



This drawing and all information thereon is the property of Hydro Engineering, Inc., and is confidential and must not be made public or copied. This drawing is loaned subject to return upon demand and is not to be used directly or indirectly in any way detrimental to our interests. Copyright © Hydro Engineering, Inc. - All rights reserved.

**HYDRO ENGINEERING INC.**  
865 W. 2600 S., SALT LAKE CITY, UT 84119

**HYDROBOOTH (VENTED)**

PROJECT/DWG TYPE SPECIFICATIONS	DRWN DNS	DWG FILE ...CAD\SPECS\BOOTH\VENTED\SPECS.DWG
HYDRO ENGINEERING PART NO. XXXXXX	DWG P/N: SDBTHVENT	DATE 04/20/12